

**LED High Bay Light**  
Instruction Manual

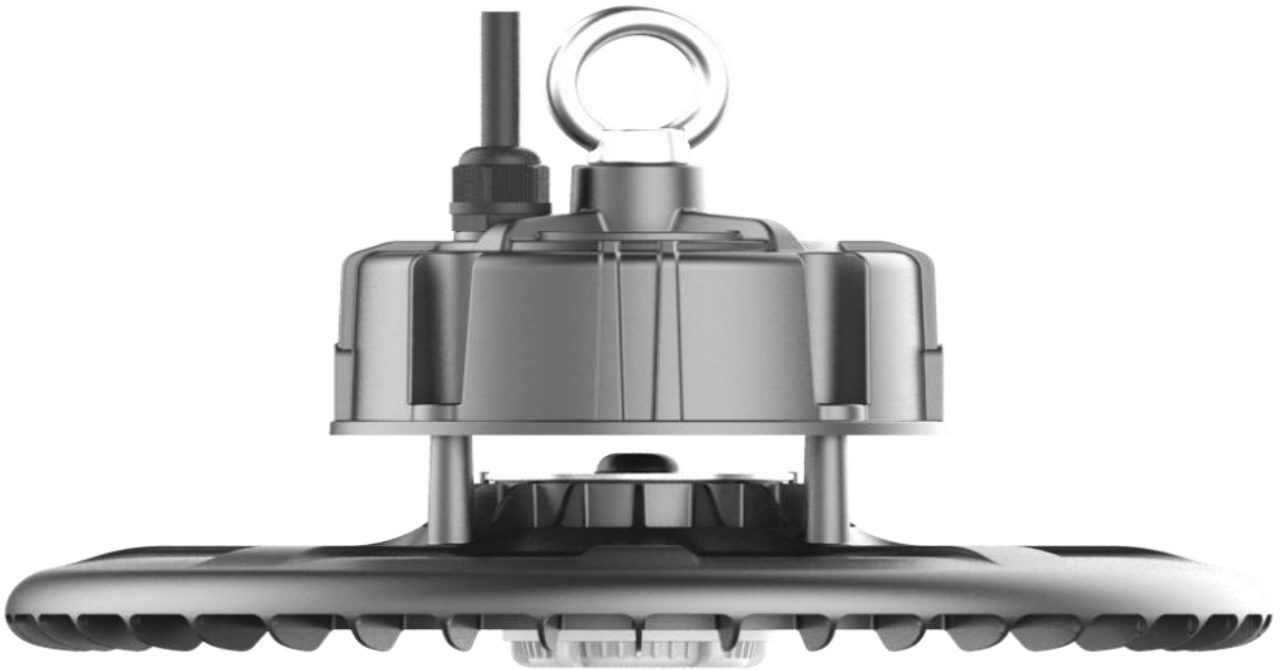

## VHB Series

**Smooth Body • Dust Free • Waterproof**  
Sensor pluggable intelligent design, Easy to upgrade





# Installation Instructions

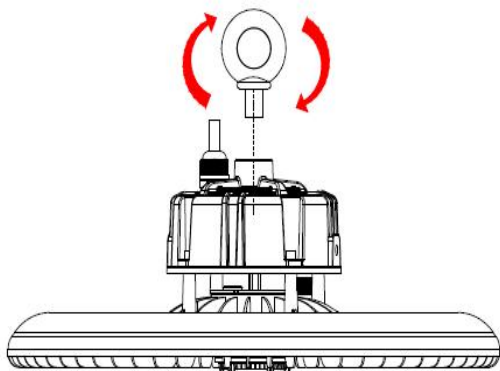

1. Install the eyebolt into the fixture

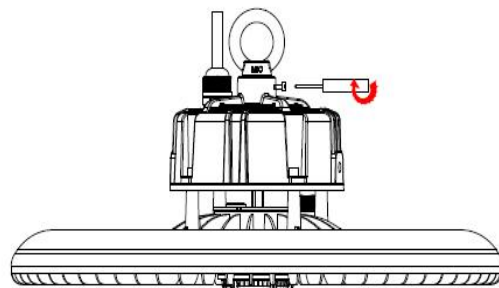

3. Attach the eyebolt to a secure structure.

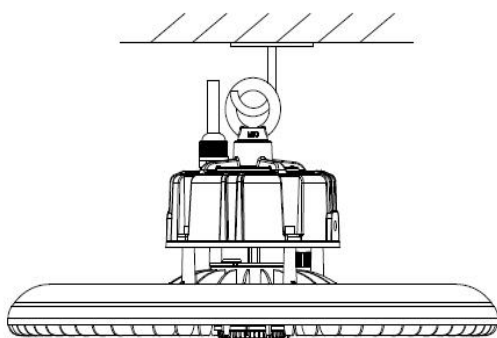

2. Secure the eyebolt with the locking screw.

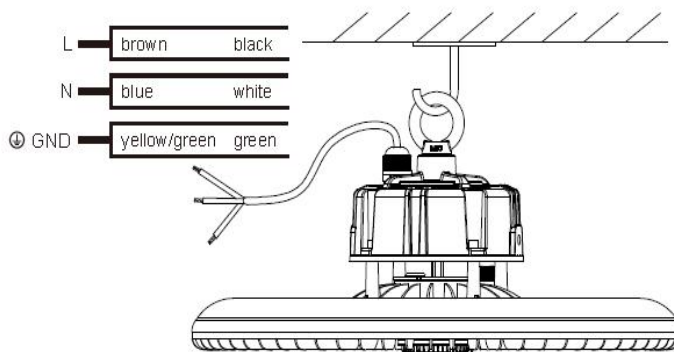

4. Connect the fixture input leads to the supply wire leads.